

Specification Data

TYPE **F** TURBO-RING FORCED DRAFT BURNERS **F22**

FORTY-TWO MILLION BTU/HR TURBO- RING FORCED DRAFT BURNER
Air or Steam Atomization - No. 2 thru 6 Fuel Oil and Natural or LP Gas

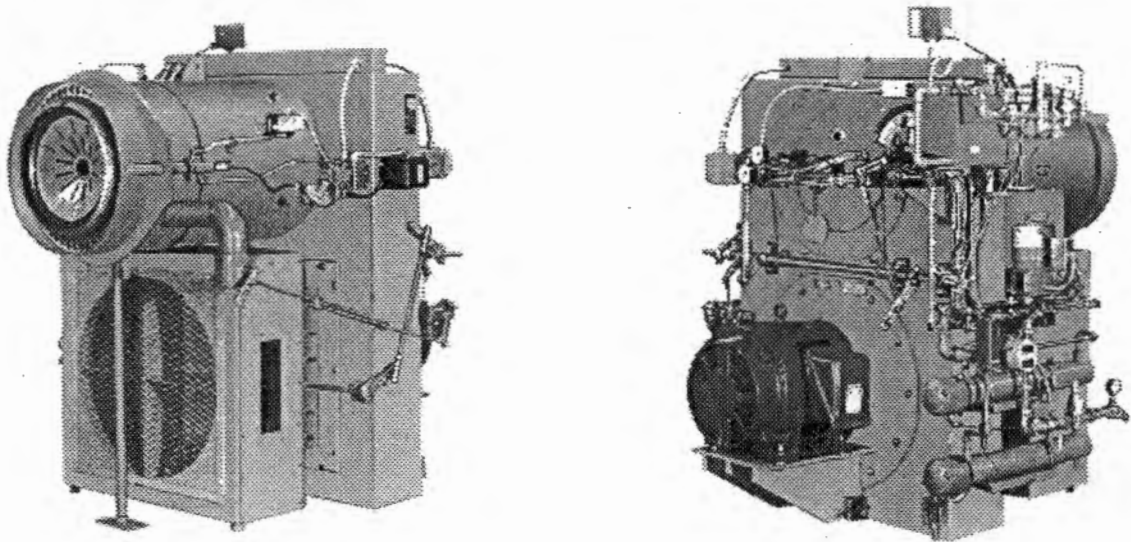

TYPICAL DUAL-FUEL BURNER WITH GAS AND AIR, OR STEAM ATOMIZING OIL SYSTEM

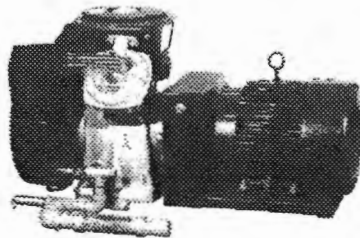

AIR COMPRESSOR

NOTE

Air compressor is standard with air atomizing systems only. It is optional (extra cost) for steam atomizing units. Oil, gas and air pressure gauges are optional.

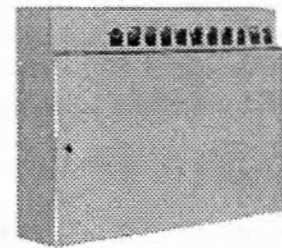

CONTROL CABINET

Burner Numbering System

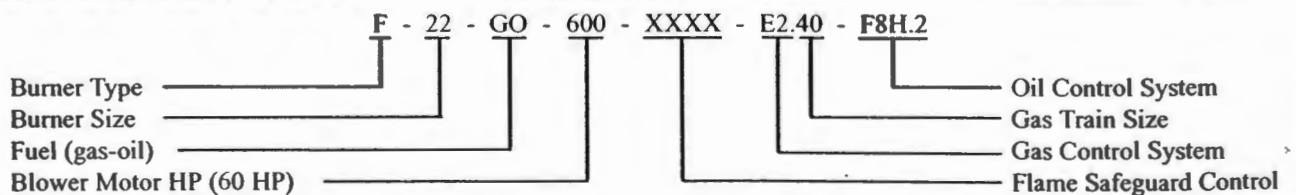

- 1 See Catalog Sheet 1-gen-10.1 for burner numbering.
- 2 Use Order Entry and Equipment Pricing Form 1196 when placing order.

Application Data

- For firetube or watertube applications to 1000 boiler HP.
- UL Listed for No. 2 - No. 6 fuel oils and natural gas. FM and IRI versions available on request.
- Turndown ratios of 5 to 1 at 1000 boiler HP and 4 to 1 at 800 boiler HP.
- Includes control cabinet and air compressor. Oil pump and gas train systems available at extra cost. Refractory front plate is optional and priced by factory at time of request for quotation.
- Fuel changeover by manual or automatic switching.
- Factory wired, assembled and tested.
- Applications must have a combustion area at least 50 inches in diameter by 224 inches long. Two-pass firetube boilers must have a minimum of 20 inches turnaround and three-pass must have a minimum of 24 inches turnaround.
- All frontplates must be built by or to JZ/GP specifications.
- All applications require prior JZ/GP Factory Approval.

Specifications and Capacities

Burner Numbers	Max. Firing Rate @ 6 Inches W. C. Max. Pressure		Burner Blower Motor		Air Atomization @ 45 PSIG			Electric Heaters	Approximate Shipping Weight	
	Gas	Oil			Air Compressor		KW		Burner W/Control Cabinet & Air Compressor	Frontplate
	Btu/Hr.	GPH	HP	RPM	Model	HP		RPM		
F22.9	38 Million	250	50	3450	LE55	7.5	1725	(2 ea) 10	3000	2000
F22	42 Million	280	60						3100	
	1 5	1 2	3		3		3		4	

- 1 Capacity up to 2000 ft. above Mean Sea Level.
- 2 Oil ratings based on 150,000 Btu/U.S. Gallon for heavy oil.
- 3 Standard voltage 240/480-60-3.
- 4 Weight will be determined by fuel(s) to be fired and accessories ordered. Weights shown are for a combination gas-oil burner with control cabinet and air compressor. Frontplates are shown separately.
- 5 A minimum of 5 pounds gas pressure is required at the inlet to the gas system.

Burner Start-up

- Start-up will be performed by JZ/GP Factory Personnel at additional cost. Others may be approved for start-up providing they have been qualified for each boiler application.

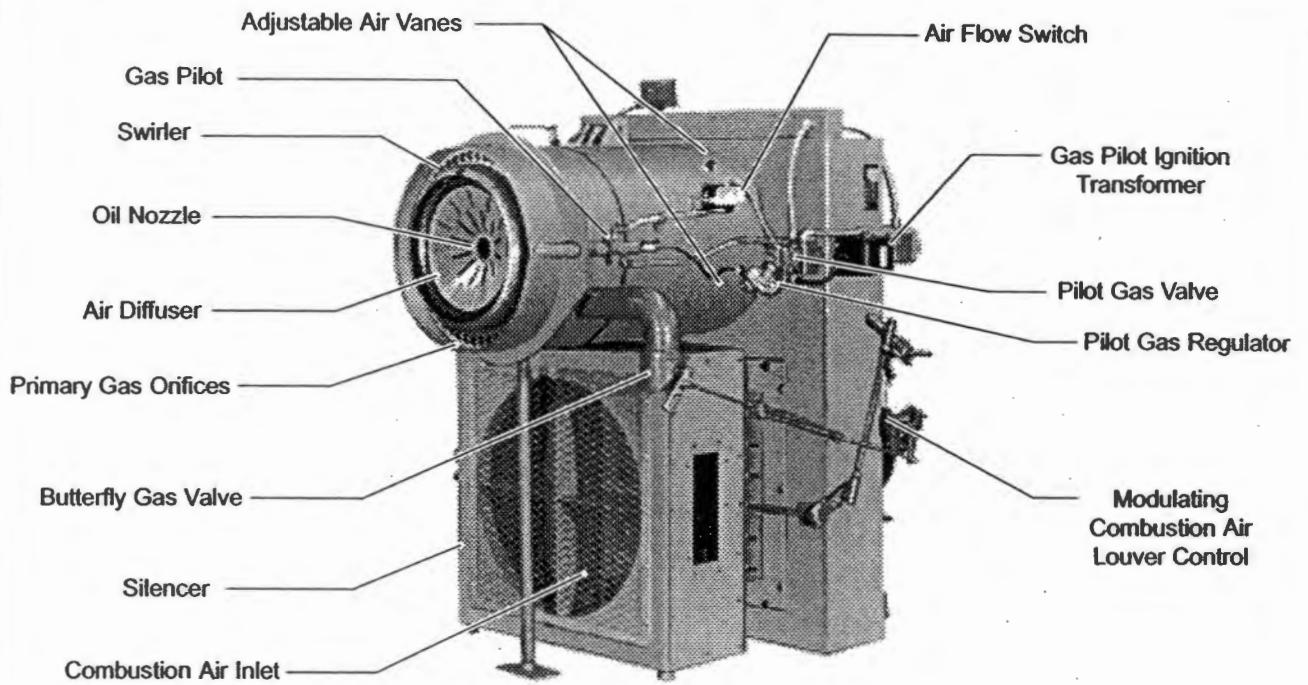

FRONT VIEW, F22

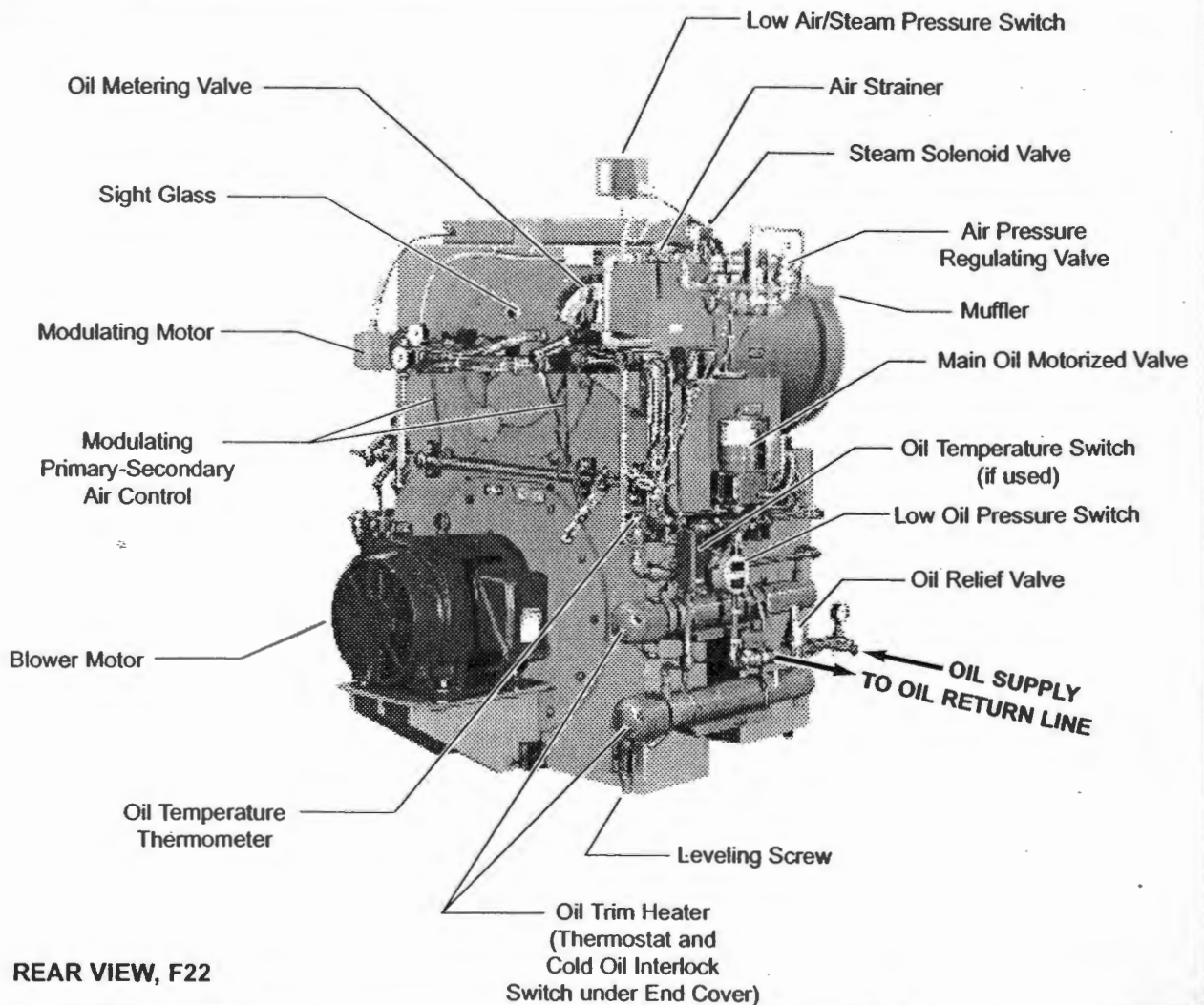

REAR VIEW, F22

Dimensions

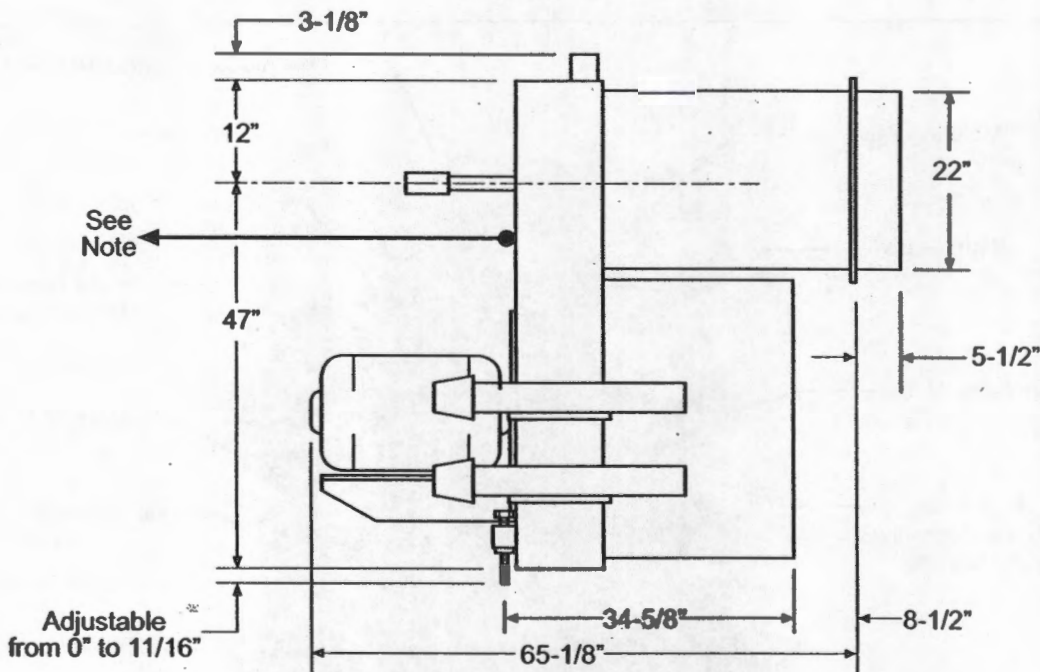
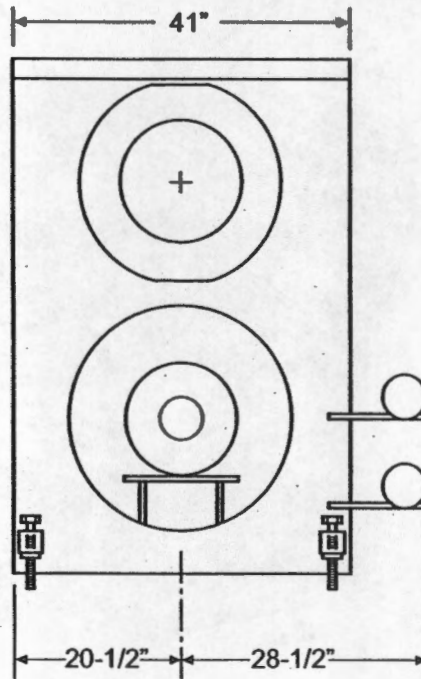

NOTE

42" plus burner nose length (5-1/2" standard) is required behind the burner to remove the oil drawer assembly.

NOTE

Dimensions shown cover the most commonly used burners within each size. These dimensions are typical and subject to change without notice. Request a certified print for specific dimensions.